

Crash Rails/Bumper Guards

KOROSEAL Wall Protection Systems Korogard® C600-Series Crash Rail

1. Locate and install **Korogard®** Crash Rail in accordance with architectural drawings and specifications. When required, **Korogard** shop drawings should be used in conjunction with these documents.
2. Lay out the work to be completed, including all component parts, along the base of the wall. Check the material for any damage that may have occurred during shipment and/or handling at the job site.
3. Snap a chalk line at the proper location on the wall to ensure a level installation. Chalk line should be calculated to the center line of the wall fasteners.
4. Place the retainer in the proper position on chalk line and mark hole locations using the proper bit size for the selected wall fasteners.

Note: If the aluminum retainer has been supplied in stock lengths, it will be necessary for it to be field-cut. Determine the allowances necessary for door jambs, corner conditions, etc. (see next page) and cut retainer to proper length. Drill proper size holes at center of retainer 3" (76.2mm) in from each end and all intermediate locations not to exceed 32" (812.8mm) O.C.

5. Attach connector plates to ends of retainer using 1" (25.4mm) pan head screws.
6. Attach ends and corners with #10 x 1" (25.4mm) hex head screws.
7. Attach splice joints with #10 x 1-1/2" (38.1mm) machine screws, washers, and nuts.
8. Mount assembly to wall using proper fasteners (not included). Tighten securely.

Note: Prior to installation of the Korogard cover, make sure that all fasteners are secure and properly seated.

9. Hold the **Korogard** cover at an angle and place the top of the cover behind the top of the retainer. Make sure that the cover is placed in the proper position and snap-fit the **Korogard** cover onto the aluminum retainer by placing hands downward and applying pressure with the heel of each hand to force the cover onto the retainer. Continue along until the complete length of the cover is securely installed.
10. If you have any questions during installation, please call your local **Korogard** representative.

Note: If the Korogard cover has been supplied in stock lengths, it will be necessary for it to be field-cut. Determine the distance from inside cap to inside cap. If this distance exceeds stock length, position seam of profile directly over the splice (connector plates) of the aluminum retainer. It is recommended that the Korogard cover be cut slightly oversize to provide proper alignment between the end caps.

Mounting cushions vary based on model number:
C600 Flush Mount
C620 1/8" (3.18mm) Mounting Cushion
C630 1/2" (12.7mm) Mounting Cushion (shown)
C640 1-1/2" (38.1mm) Mounting Brackets
C650 2" (50.8mm) Mounting Brackets

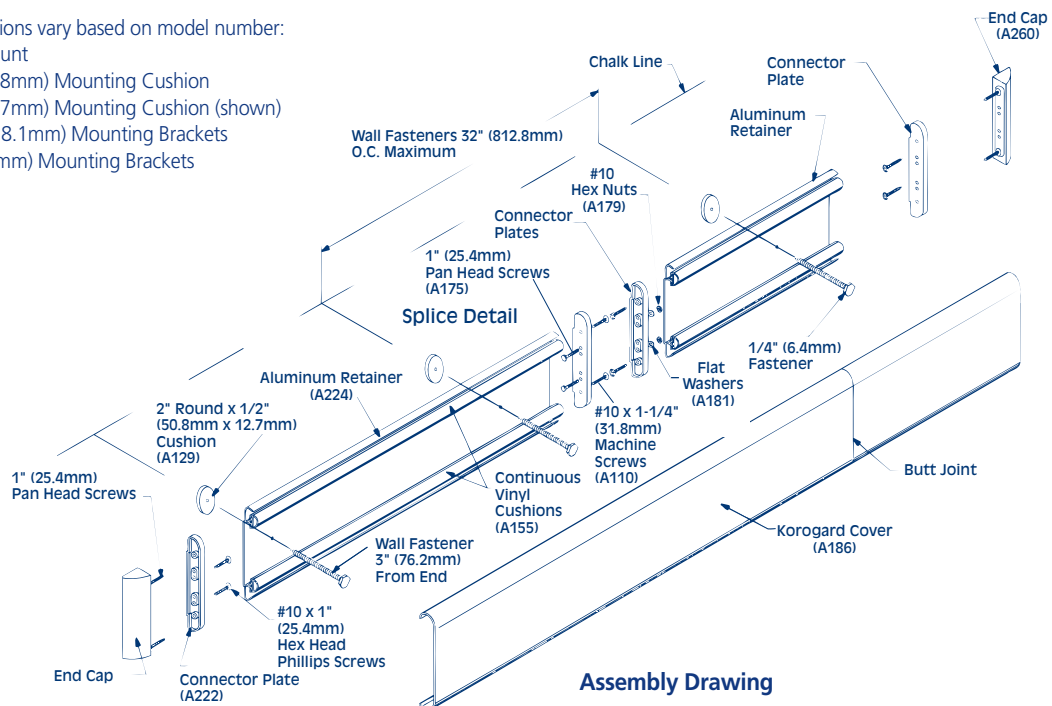

Crash Rails/Bumper Guards

KOROSEAL Wall Protection Systems Korogard® C600-Series Crash Rail

Installation Dimensions for C600-Series Crash Rail

Note: Includes Crash Rail Model C600 Flush Mount
Model C620 1/8" (3.2mm) Mounting Cushion
Model C630 1/2" (12.7mm) Mounting Cushion
Model C640 1-1/2" (38.1mm) Mounting Brackets
Model C650 2" (50.8mm) Mounting Brackets

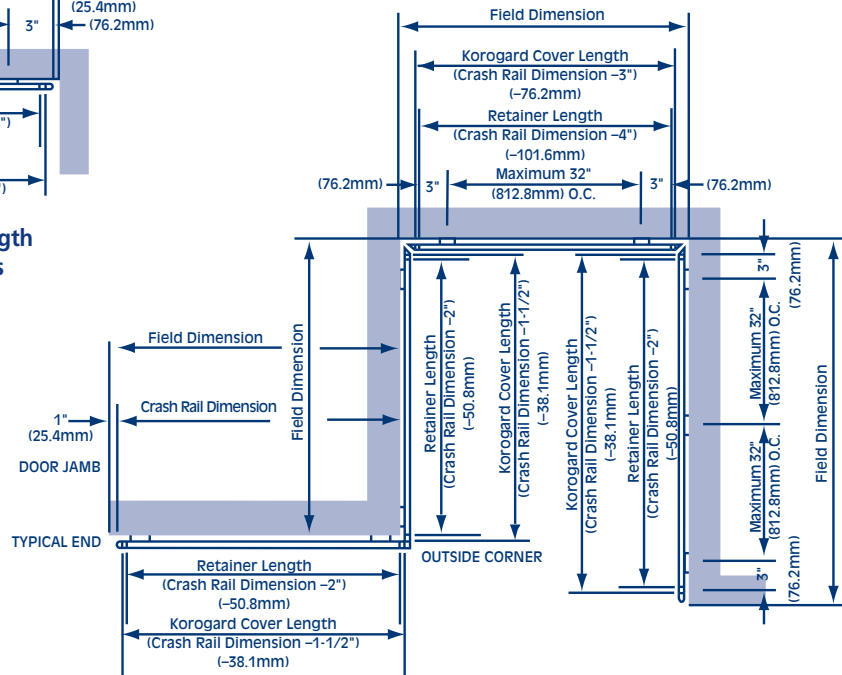
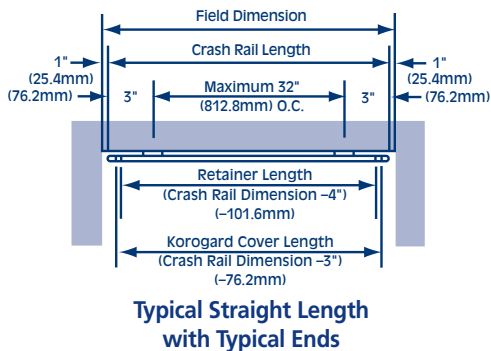
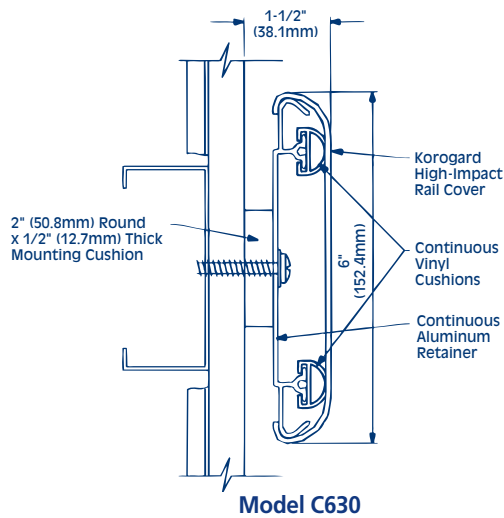
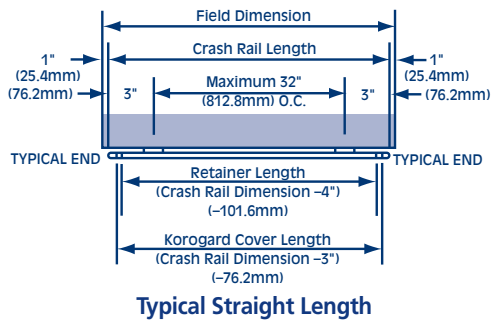

KOROGARD®
WALL PROTECTION SYSTEMS