

KOROGARD G815, G875, & G915 EXTRUDED CORNER GUARDS



Korogard Extruded Corner Guards are an economical yet durable option for corner protection. Easily installed, these guards are .078" (1.98mm) thick vinyl with 3/4" (19.1mm), or 1-1/2" (38.1mm) wings. The wings are tapered back, providing a finished look to any installation. These can also be manufactured with a self adhesive foam tape making them model number G915, and G975. The G815 is available as G81E, a Korogard ETS product manufactured with a unique blend of high-performance materials.

Korogard Extruded Corner Guards are backed by a limited five-year warranty. All Corner Guards are Class A fire rated and meet national building code standards. All Korogard protective products color-coordinate with a multitude of Koroseal Wallcoverings for a systems approach to wall protection.

For more information on Korogard Corner Guards or the Koroseal Wall Protection System, please call your local Korogard distributor

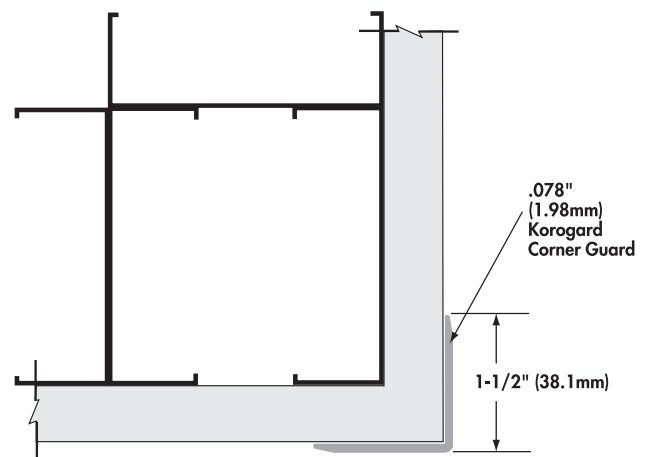
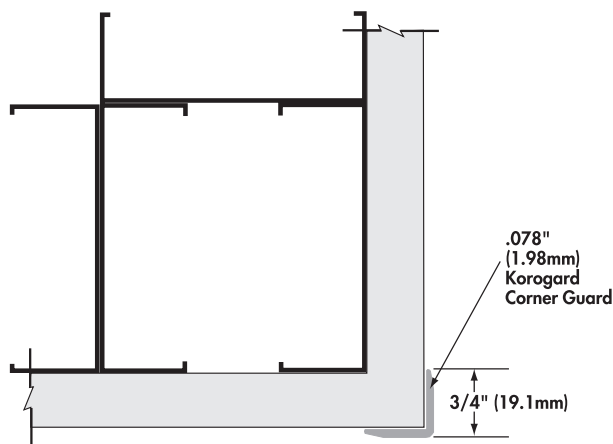
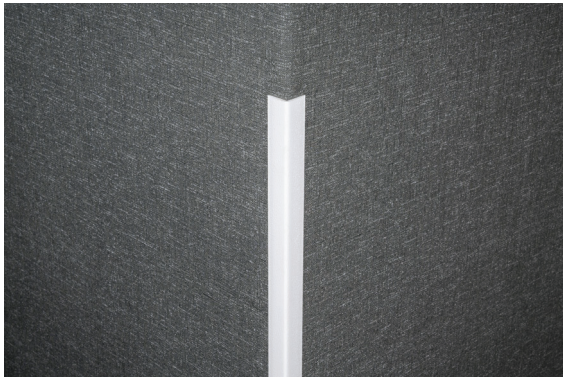

**KOROGARD
G815, G875, & G915
EXTRUDED CORNER GUARDS**



SECTION 10 26 00 CORNER GUARDS

PART 1 - GENERAL

1.1 SECTION INCLUDES

- A. 1-1/2" (38.1 mm) x 1-1/2" (38.1 mm), and 3/4" (19.1 mm) x 3/4" (19.1 mm) Surface Adhered Extruded Corner Guards.

1.2 SUBMITTALS

- A. Submit in accordance with Section 01 33 00 – Submittals.
- B. Product Data: Submit manufacturer's product data.
- C. Samples: Submit for approval 12" (304.8mm) long sample of each color specified.
- D. Test Reports: Submit manufacturer's test reports and certification indicating compliance with applicable building code requirements

1.3 QUALITY ASSURANCE

- A. Comply with NFPA 101® for interior finish materials. Smoke developed less than 450 and flame spread of 25 or less in accordance with ASTM E 84.

1.4 DELIVERY, STORAGE, AND HANDLING

- A. Delivery: Deliver materials to site in manufacturer's original, unopened containers and packaging with labels clearly identifying product name and manufacture.
- B. Storage: Store materials in a clean, dry location protected against damage of any kind.

PART 2 - PRODUCTS

2.1 MANUFACTURER

- A. Koroseal Wall Protection Systems, A Division of Koroseal Interior Products.

2.2 CORNER GUARDS

- A. Koroseal "Korogard" Series G815, G875, and G915: Extruded Corner Guard adhered to substrate corner with glue or tape. Exposed surfaces shall be free of wrinkling, chipping, discoloration, or other imperfections.
 - 1. Dimensions
 - a. Leg length: 1-1/2" (38.1mm) - G815, & G915; 3/4" (19.1mm) - G875
 - b. Angle: 90°
 - 2. Profile: High-impact vinyl acrylic extrusion, nominal .078" (1.98 mm) thick. Class A fire rating, when tested in accordance with ASTM E 84.
 - 3. Extrusion: Pebble grain finish. Contains EPA registered Micro Chek antimicrobial agent.
 - 4. Adhesion: Manufacturer recommended contact cement - G815, and G875; Manufacturer applied adhesive-backed tape - G915.

PART 3 - EXECUTION

3.1 EXAMINATION

- A. Verify by examination that wall surfaces are acceptable to receive the specified guard systems. Notify the Architect in writing if wall surfaces are not acceptable. Do not begin installation until unacceptable conditions have been corrected.

3.2 INSTALLATION

- A. Install Corner Guards to wall securely in accordance with manufacturer's written instructions.
- B. Install Corner Guards accurately in location, alignment, and elevation,