

G100-SERIES SURFACE-MOUNTED CORNER GUARDS



Korogard G100-Series Corner Guards consist of a formidable 2" (50.8mm) vinyl 1/4" (6.35mm) radius cover mounted over a continuous retainer. Korogard Corner Guards are an attractive and durable solution to unsightly, damaged corners. G100-Series Surface-Mounted Corner Guards provide support in medium- to high-impact areas.

Korogard G100-Series Corner Guards are backed by a limited five-year warranty. All Corner Guards are Class A fire rated and meet national building code standards. All Korogard linear profiles color-coordinate with a multitude of Koroseal Wallcoverings for a systems approach to wall protection.

For more information on Korogard Corner Guards or the Koroseal Wall Protection System, please call your local Korogard distributor.

G100 SERIES ACCESSORY ITEMS

G101 Standard End Cap

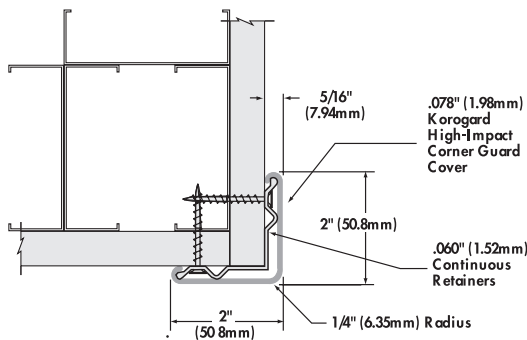

G100

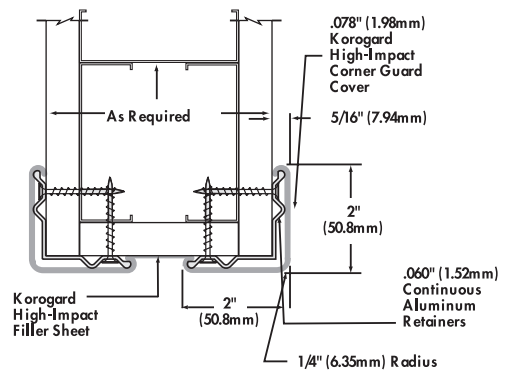

G110

G100-SERIES SURFACE-MOUNTED CORNER GUARDS



SECTION 10 26 00 CORNER GUARDS

PART 1 - GENERAL

I.1 SECTION INCLUDES

- A. 2" (50.8mm) x2" (50.8mm) Corner Guards.

I.2 SUBMITTALS

- A. Comply with requirements of Section 01 33 00 – Submittals.
- B. Product Data: Submit manufacturer's product data.
- C. Shop Drawings: Submit shop drawings showing components, dimensions, and anchorage details.
- D. Samples: Submit 12" (304.8mm) long sample of each model and color specified, including end caps, for Architect's approval.
- E. Certification: Submit manufacturer's certification indicating compliance with applicable building code requirements.

I.3 QUALITY ASSURANCE

- A. Comply with NFPA 101® for interior finish materials. Smoke developed less than 450 and flame spread of 25 or less in accordance with ASTM E 84.

I.4 DELIVERY, STORAGE, AND HANDUNG

- A. Delivery: Deliver materials to site in manufacturer's original, unopened containers and packaging with labels clearly indicating manufacturer and material.
- B. Storage: Store materials indoors in a clean, dry area protected from damage and in accordance with manufacturer's instructions.
- C. Handling: Protect materials during handling and installation to prevent damage.

PART 2 - PRODUCTS

2.1 MANUFACTURER

- A. Koroseal Wall Protection Systems, A Division of Koroseal Interior Products.

2.2

2.3 CORNER GUARDS SYSTEMS

- A. Koroseal "Korogard" G100-Series Corner Guard: Corner Guard mounted over continuous retainer. Exposed surfaces shall be free of wrinkling, chipping, discoloration, or other imperfections.
 - 1. Dimensions
 - a. Leg Length: 2" (50.8mm).
 - b. Angle: 90°.
 - 2. Profile: High-impact vinyl acrylic extrusion locked in place, nominal 0.078" (1.98mm) thick. Class A fire rating, tested in accordance with ASTM E 84.
 - 3. Extrusion: G100: Pebble grain finish; G10F: Smooth finish. Contains EPA-registered Micro-Chek antimicrobial agent.
 - 4. Retainer: Continuous retainer along entire length of Corner Guard, nominal 0.060' (1.52mm) thick.
 - a. 6063-T5 aluminum (G100, G110).
 - 5. End Caps: Injection-molded unit of color and texture similar to that of Corner Guard.

PART 3 - EXECUTION

3.1 EXAMINATION

- A. Inspect wall surfaces to receive Corner Guards. Notify the Architect in writing if wall surfaces are not acceptable. Do not begin installation until unacceptable conditions have been corrected.

3.2 INSTALLATION

- A. Install Corner Guards to walls securely in accordance with manufacturer's written instructions.
- B. Install Corner Guards accurately in location, alignment and elevation